

### Portable Ladders

All portable ladders used by University faculty, staff and students will meet the following requirements:

- Rated greater than the weight of the worker and any tools or equipment carried by the worker;
- Appropriate ladder style for the job (i.e. step ladders will not be used in a folded position, step ladders will be tall enough to perform work without standing on the top two steps, extension ladders will extend a minimum of three feet above the discharge point, etc.);
- Metal ladders will not be used near electrical lines or sources; and
- Inspected prior to each use.

Ladders must be set up on a surface that is firm, flat and is not slippery. The top of extension ladders must be against a solid, fixed surface and extend at least three feet above the landing surface.

Extension ladders will be set up using the 4-to-1 principal (base of the ladder placed at a distance from the wall that is equal to one fourth of the height that the ladder is extended). When employees are on extension ladders at heights of 20 feet or higher, either a second person must steady the ladder base or the top of the ladder must be effectively tied off to a sound anchor point.

Ladders are rated according to the maximum weight they can safely support. The five rating classes are shown in the table below. Keep in mind that these ratings are for the combined weight of the user **and** any materials carried.

<u>Type</u>	<u>Rating</u>	<u>Description</u>
1AA	375 lbs.	Extra-heavy-duty industrial ladder
1A	300 lbs.	Heavy-duty industrial ladder
1	250 lbs.	Heavy-duty industrial ladder
2	225 lbs.	Medium-duty commercial ladder
3	200 lbs.	Light-duty household ladder

**Ladder Inspections**

Portable ladders must be inspected prior to each use.

**Ladder Condition**

- This is the proper ladder type for the job
- No cracks in rungs or sides of ladder
- No loose rungs
- No slippery contaminants on rungs or side rails
- Connection hardware is in good condition
- No broken locks or pulleys
- No damage to ladder feet/base
- No frayed or worn ropes
- Frame is not bent, warped or uneven

**Ladder Setup****Extension Ladders**

- Firm, level ground
- Firm/proper top resting point
- Top extends at least four rungs above resting point if accessing roof
- Level ladder legs
- No electrical hazards
- No horizontal forces
- Rung locking devices secure
- Area cordoned off (if necessary)
- If 20 or more feet high, secure top of ladder or have a second person stabilize the base

**Step Ladders**

- Firm, level ground
- Reaches proper height
- No electrical hazards
- No horizontal forces required
- Work zone barricaded (if necessary)

### Fixed Ladders

All fixed ladders used by University faculty, staff and students will meet the following requirements:

- Must be capable of supporting their maximum intended load;
- The minimum perpendicular distance from the centerline of the steps or rungs, or grab bars, or both, to the nearest permanent object in back of the ladder is 7 inches, except for elevator pit ladders, which have a minimum perpendicular distance of 4.5 inches;
- Grab bars do not protrude on the climbing side beyond the rungs of the ladder that they serve;
- The side rails of through or sidestep ladders extend 42 inches above the top of the access level or landing platform served by the ladder. For parapet ladders, the access level is:
  - The roof, if the parapet is cut to permit passage through the parapet; or
  - The top of the parapet, if the parapet is continuous;
- For through ladders, the steps or rungs are omitted from the extensions, and the side rails are flared to provide not less than 24 inches and not more than 30 inches of clearance. When a ladder safety system is provided, the maximum clearance between side rails of the extension must not exceed 36 inches;
- For side-step ladders, the side rails, rungs, and steps must be continuous in the extension (see Figure 2 below);

Figure 2. Side-Step Fixed Ladder Sections

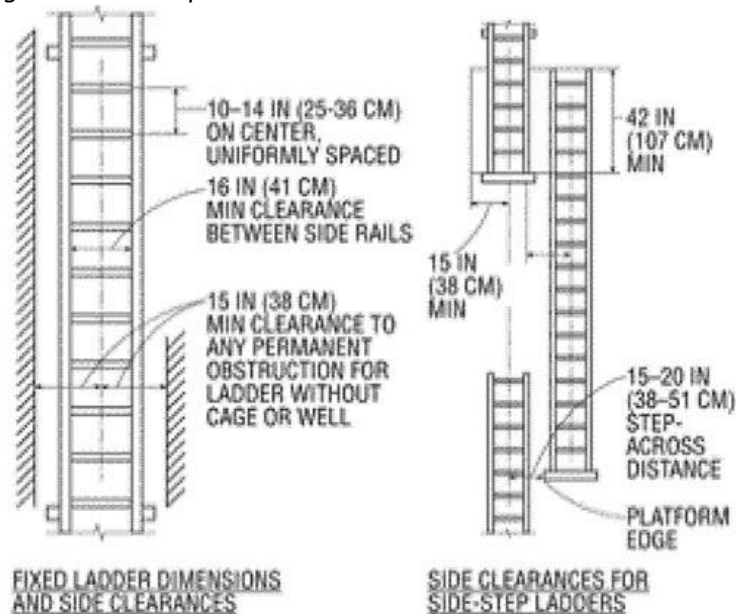

- Grab bars extend 42 inches above the access level or landing platforms served by the ladder;
- The minimum size (cross-section) of grab bars is the same size as the rungs of the ladder;
- When a fixed ladder terminates at a hatch (see Figure 3 below), the hatch cover:
  - Opens with sufficient clearance to provide easy access to or from the ladder; and
  - Opens at least 70 degrees from horizontal if the hatch is counterbalanced

Figure 3. Example of Counterbalanced Hatch Cover at Roof

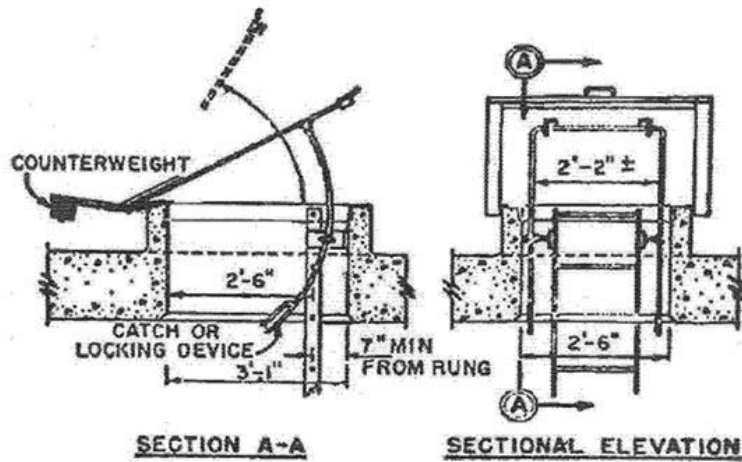

- Individual-rung ladders are constructed to prevent the employee's feet from sliding off the ends of the rungs (see Figure 4 below);

Figure 4. Individual Rung Ladder

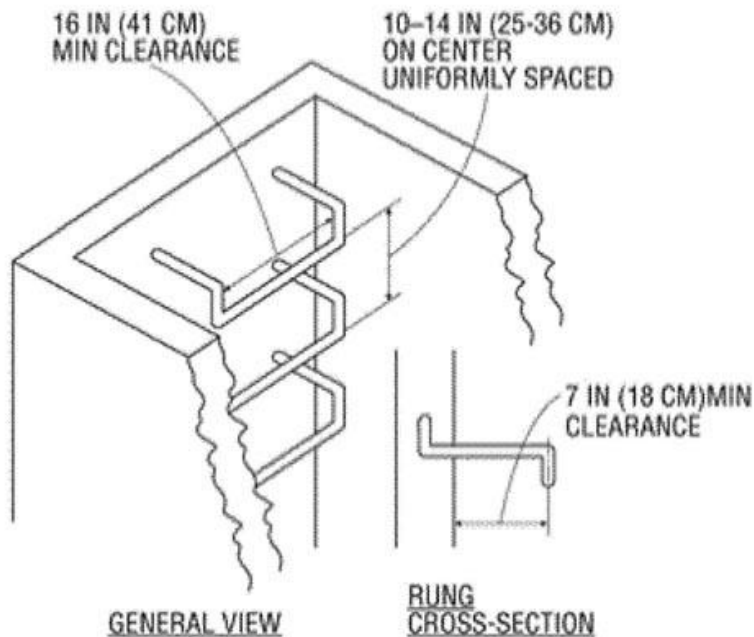

- Fixed ladders having a pitch greater than 90 degrees from the horizontal are not used;
- The step-across distance from the centerline of the rungs or steps is:
  - For through ladders, not less than 7 inches and not more than 12 inches to the nearest edge of the structure, building, or equipment accessed from the ladders; and
  - For side-step ladders, not less than 15 inches and not more than 20 inches to the access points of the platform edge;

- Fixed ladders that do not have cages or wells have:
  - A clear width of at least 15 inches on each side of the ladder centerline to the nearest permanent object; and
  - A minimum perpendicular distance of 30 inches from the centerline of the steps or rungs to the nearest object on the climbing side. When unavoidable obstructions are encountered, the minimum clearance at the obstruction may be reduced to 24 inches, provided deflector plates are installed (see Figure 5 below).

Figure 5. Fixed Ladder Clearances

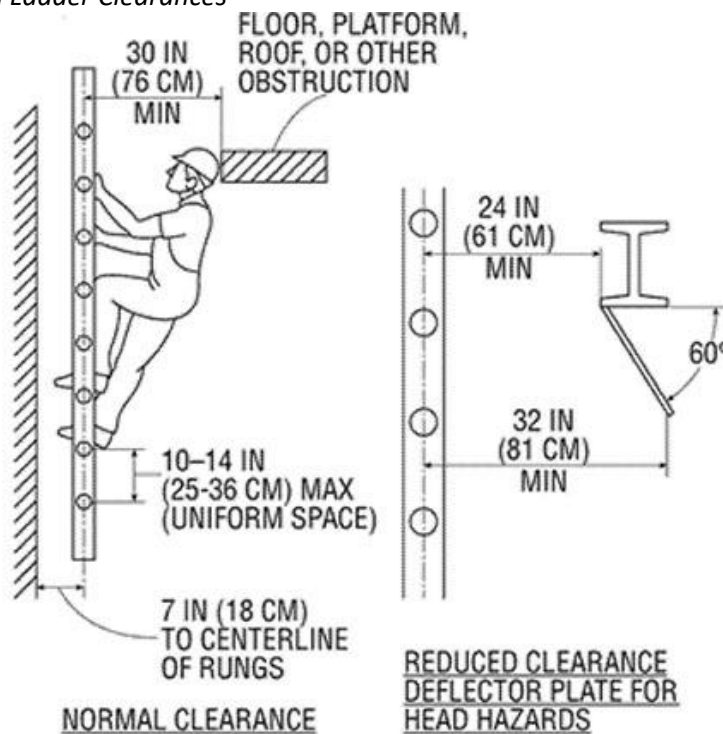

### Fixed Ladders that Extend More Than 24 Feet Above a Lower Level

- *Existing fixed ladders.* Each fixed ladder installed before November 19, 2018 is equipped with a personal fall arrest system, ladder safety system, cage, or well;
- *New fixed ladders.* Each fixed ladder installed on and after November 19, 2018, is equipped with a personal fall arrest system or a ladder safety system;
- *Replacement.* When a fixed ladder, cage, or well, or any portion of a section thereof, is replaced, a personal fall arrest system or ladder safety system is installed in at least that section of the fixed ladder, cage, or well where the replacement is located; and
- *Final deadline.* On and after November 18, 2036, all fixed ladders are equipped with a personal fall arrest system or a ladder safety system.

When a one-section fixed ladder is equipped with a personal fall protection or a ladder safety system or a fixed ladder is equipped with a personal fall arrest or ladder safety system on more than one section, then:

- The personal fall arrest system or ladder safety system provides protection throughout the entire vertical distance of the ladder, including all ladder sections; and
- The ladder has rest platforms provided at maximum intervals of 150 feet;
- The employer must ensure ladder sections having a cage or well:
  - Are offset from adjacent sections; and
  - Have landing platforms provided at maximum intervals of 50 feet; and
- The employer may use a cage or well in combination with a personal fall arrest system or ladder safety system provided that the cage or well does not interfere with the operation of the system.

### Cages, Wells, and Platforms Used with Fixed Ladders

- Cages and wells installed on fixed ladders are designed, constructed, and maintained to permit easy access to, and egress from, the ladder that they enclose (see Figures 5 and 6 below);
  - Cages and wells are continuous throughout the length of the fixed ladder, except for access, egress, and other transfer points;
  - Cages and wells are designed, constructed, and maintained to contain employees in the event of a fall, and to direct them to a lower landing; and
  - Platforms used with fixed ladders provide a horizontal surface of at least 24 inches by 30 inches.

Figure 5. Clearances for Fixed Ladders in Wells

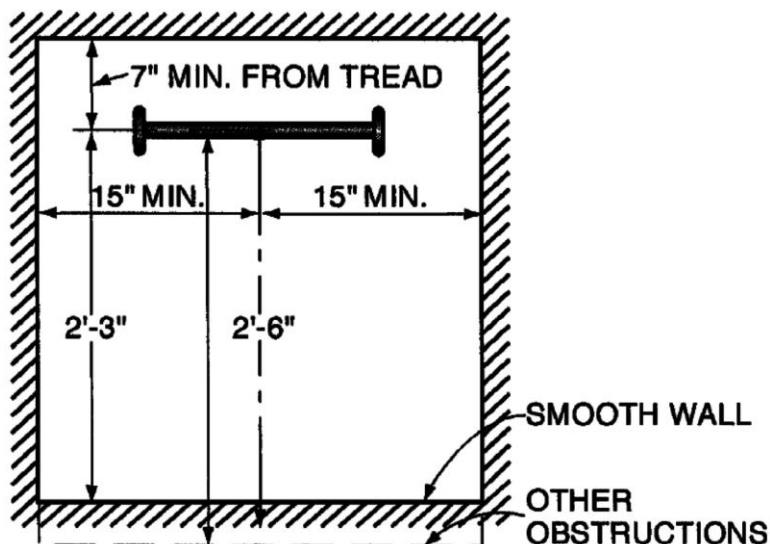



- Mountings for flexible carriers are attached at each end of the carrier and cable guides for flexible carriers are installed at least 25 feet apart but not more than 40 feet apart along the entire length of the carrier;
- The design and installation of mountings and cable guides does not reduce the design strength of the ladder; and
- Ladder safety systems and their support systems are capable of withstanding, without failure, a drop test consisting of an 18-inch drop of a 500-pound weight.